

Check Valve Pressure Testing

Product Testing & Design Qualification

NOREVA, GERMANY

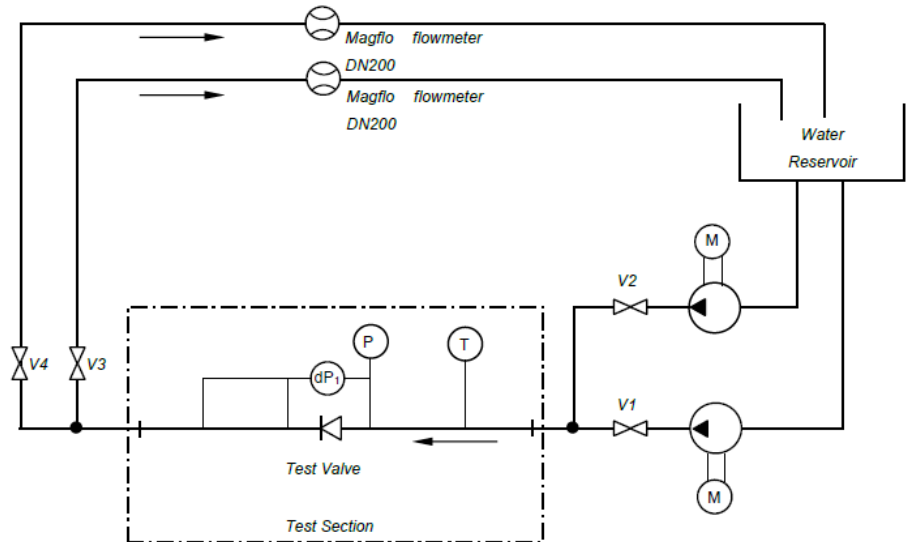

Noreva GmbH have been involved in the design, manufacture and supply of check valves for use in the hydrocarbon, energy and process industries for over 15 years.

BHR's strength in designing and building bespoke rigs for specific client projects was key to this project, which required high flow rates to be delivered for DN400 size pipework.

BHR was contracted by Noreva to undertake a series of tests to qualify the design of a new check valve. The objectives of the project were to test the check valve over a specific velocity range, monitor the steady state pressure drop across the valve and determine the pressure loss coefficient.

BHR designed, built and commissioned a test facility to provide the flow of up to 3m/s (390 l/s) capable of testing the DN400 check valve for pressure drop measurement. The rig comprised a basic flow loop with water reservoir, 2 centrifugal pumps, inlet pipework to test section, test section pipework and return pipework. Instrumentation monitoring flow, line pressure, pressure differential across the test valve, and fluid temperature were calibrated in house and traceable to national standard and a PC based DAQ system was used to monitor and record all output signals from the test rig instrumentation.

“We worked closely with the Noreva team to undertake tests to assess their new scaled up valve design. Our findings helped them identify key areas for improvement to ensure that minimal pressure was lost through the valve and fast closing speeds were achieved.”

Craig Knight
OPERATIONS MANAGER

The pressure loss characteristics determined across a range of flow velocities, with particular detail given to 1 – 2 m/s flow velocity region, showed a greater pressure loss than the client had predicted. BHR recommended a CFD analysis of the valve design be conducted to understand the cause for the higher than expected pressure loss and inform subsequent design recommendations to improve pressure loss performance.